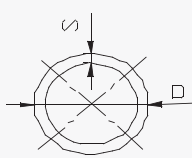
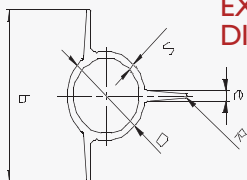
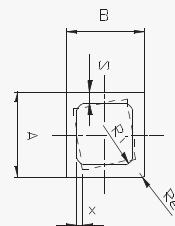

# STANDARD PROFILE TOLERANCES

## HOT EXTRUDED AND STRAIGHTENED - HOLLOW SECTION

<p><b>A</b></p>  <p><b>EXTERNAL DIAMETER D</b></p> <p>Up to 50 mm: <math>\pm 0.5</math> mm Over 50 mm: <math>\pm 1\%</math> Thickness S: <math>\pm 10\%</math> of the nominal thickness</p>	<p><b>B</b></p>  <p><b>EXTERNAL DIAMETER D</b></p> <p>Up to 50 mm: <math>\pm 0.5</math> mm Over 50 mm: <math>\pm 1\%</math> Thickness S: <math>\pm 15\%</math> Thickness of fin e: <math>\pm 0.5</math> mm Width of fin b: <math>\pm 2</math> mm (or less on agreement)</p>	<p><b>C</b></p>  <p><b>DISPLACEMENT OF INTERNAL FORM X: <math>\pm 1</math> mm</b></p> <p>The tolerances of other hollow profile shapes must be agreed after study. For all other tolerances see table for solid section profiles.</p>
--	--	--

# STANDARD PROFILE TOLERANCES

## HOT EXTRUDED AND STRAIGHTENED - SOLID SECTION

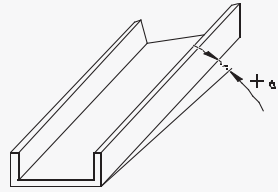
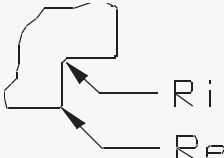
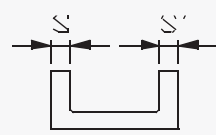
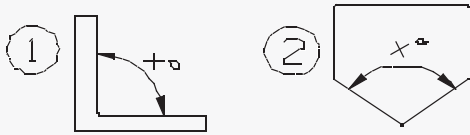
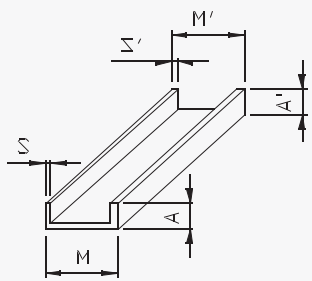
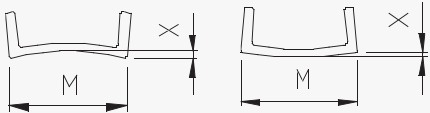
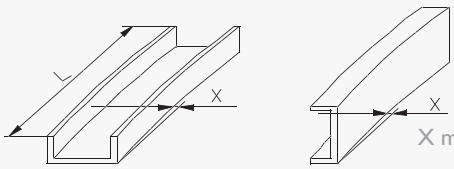
<p><b>A</b></p> <p><b>DIMENSIONAL TOLERANCES OF THE TRANSVERSE SECTION:</b></p> <p>Less than 25 mm: <math>\pm 0.5</math> mm from 25 to 75 mm: <math>\pm 0.8</math> mm from 75 to 100 mm: <math>\pm 1.0</math> mm from 100 to 125 mm: <math>\pm 1.2</math> mm over 125 mm: <math>\pm 1.4</math> mm</p>	<p><b>F</b></p> <p><b>WARP:</b></p> <p>Max. deviation of 1mm per metre, or less (on agreement) according to requirements.</p> 
<p><b>B</b></p> <p><b>MINIMUM RADII:</b></p>  <p>Ri = internal radius: minimum <math>4^{+2}_0</math> mm Re = external radius: minimum <math>1.5 \pm 0.5</math> mm</p>	<p><b>G</b></p> <p><b>DIMENSIONAL DIFFERENCES BETWEEN SYMMETRICAL PARTS:</b></p>  <p>Max difference between S and S' half tolerance of point A e.g. S = S' = <math>28 \pm 0.8</math> mm max difference 0.8 mm (hypothesis S = 27.6 S' = 28.4)</p>
<p><b>C</b></p> <p><b>ANGULAR TOLERANCES:</b></p>  <p>Type 1 case <math>\pm 1^\circ 30'</math> Type 2 case <math>\pm 0^\circ 30'</math></p>	<p><b>H</b></p> <p><b>DIMENSIONAL DIFFERENCES BETWEEN SYMMETRICAL PARTS:</b></p>  <p>Max variation: half tolerance at point A e.g.: nominal values M = M' = <math>80 \pm 1</math> mm A = A' = <math>40 \pm 0.8</math> mm S = S' = <math>15 \pm 0.5</math> mm Example: M = 79.5 M' = 80.5 A = 39.4 A' = 40.2 S = 14.75 S' = 15.75</p>
<p><b>D</b></p> <p><b>TRANSVERSE CURVATURE:</b></p>  <p>X max = 1% of M (or less on agreement)</p>	<p><b>I</b></p> <p><b>LONGITUDINAL BAR TOLERANCES:</b></p> <p>a) from production <math>\pm 1</math> metre b) fixed: <math>\pm 2</math> mm; from 0+10mm (or on request) c) multiple: + 5 mm each multiple (or on request) d) commercial: from 3 metres to 7 metres</p>
<p><b>E</b></p> <p><b>LONGITUDINAL CURVATURE:</b></p>  <p>X max. = 0,15% of L</p>	

The tolerances shown are purely indicative of the capabilities of the production process, more specific indications are given in the technical drawings of the profiles.